



Status of the SLAC/MSU SRF Gun Development Project

Samuel J. Miller
Mechanical Engineering Department Manager



U.S. DEPARTMENT OF
ENERGY

Office of
Science

Outline

- This talk will focus on:
 - SRF Gun Project Overview
 - SRF Gun Cryomodule Performance Goals
 - SRF Gun Cryomodule Design
 - SRF Gun Cryomodule Fabrication Plans/Status
 - SRF Gun Cryomodule Testing Plans
 - Summary

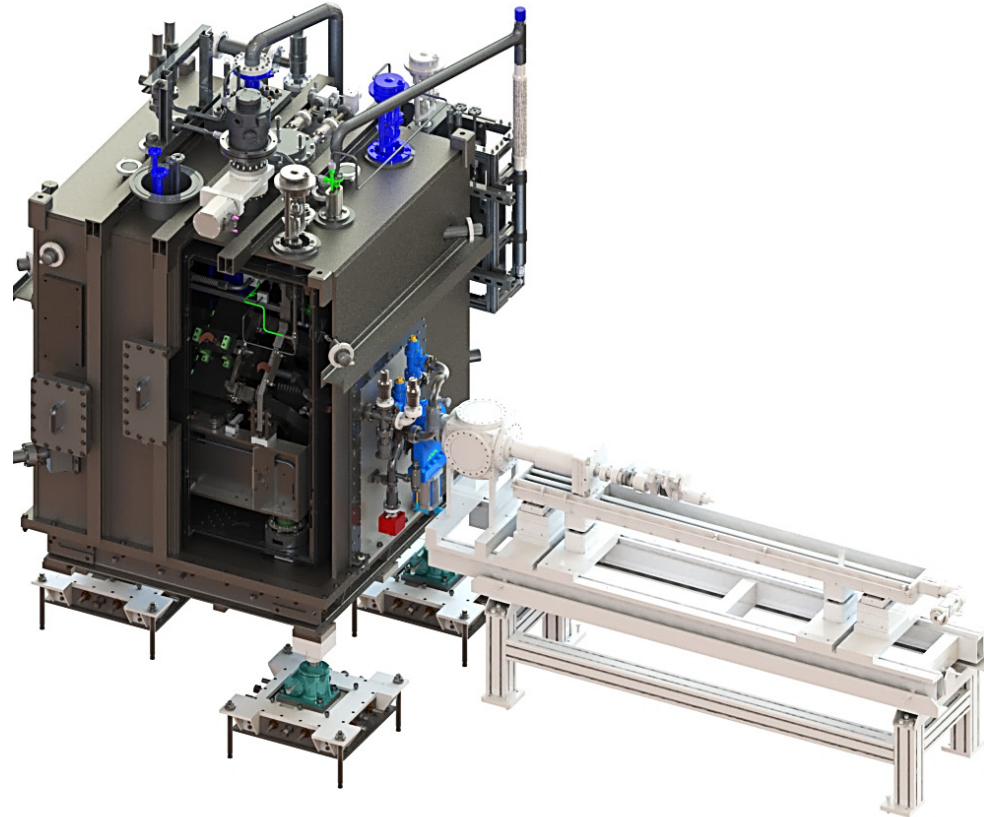

SRF Gun Project Overview

- SLAC established a collaboration to design, construct and test a quarter-wave SRF gun within four years with FRIB at MSU
- Two versions of the RF cavity are to be manufactured, one with a cathode plug port and one without it
- Fundamental power coupler (FPC): The FPC(s) should be multipacting and field emission free, and not produce significant asymmetric fields in the cavity
- Cavity tuner: Slow and fast tuners should be designed to ensure the gun operates at the nominal frequency within the detuning budget
- Cathode stalk and load lock: The cathode stalk is to be designed to provide an RF short while minimizing the heat load to the helium bath
- Emittance compensation solenoid: the specified solenoid magnet location is close to the gun anode

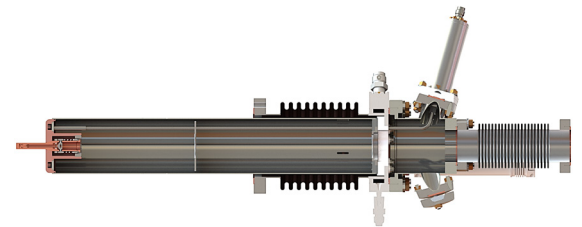
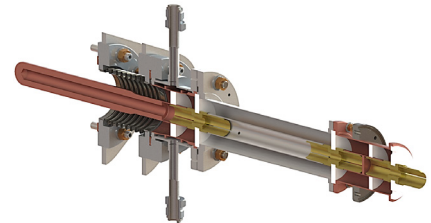

SRF Gun Cryomodule Performance Goals

Parameter	Units	Value
Operating Temperature	K	4.2
Cavity Frequency at 4.2K, 1 bar	MHz	185.7
Cathode Gradient (Nominal/Maximum Operating)	MV/m	> 30/35
Integrated E_z Field at 30 MV/m Gradient	MV	> 1.6
Captured Dark Current at 30 MV/m Gradient	nA	< 10
Distance from Cathode to Anode*	mm	70
Length of Solenoid Magnetic Yoke*	mm	124
Exit Beam Pipe Radius	mm	20
Cavity Q_0		$> 1 \times 10^9$
RF Coupler Q_{ext}^*		10^7
Static Heat Load at 4.5 K	W	< 25
Cavity Vacuum Pressure at Room Temperature	torr	$< 1 \times 10^{-9}$
Helium Vessel Leak Rate at Room Temperature	torr-liter/sec	$< 1 \times 10^{-7}$
*SLAC Design Values		

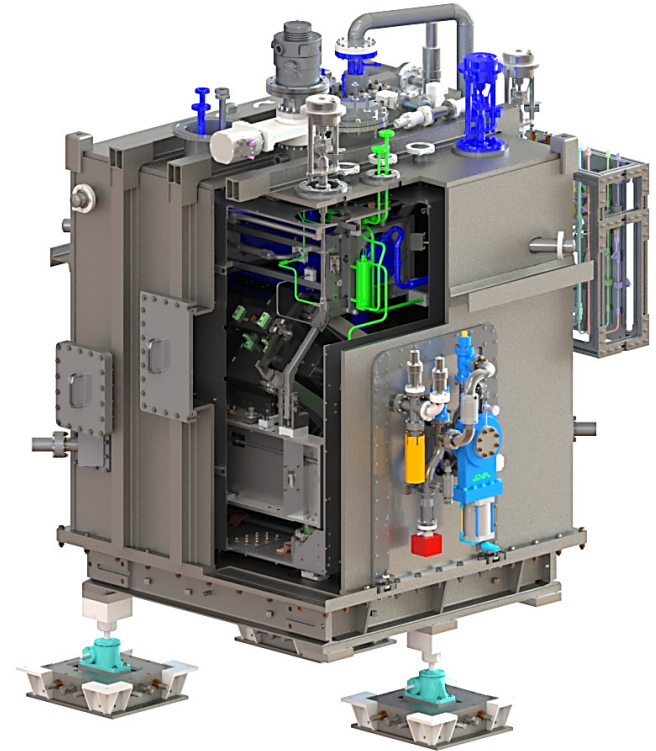

Scope Between Partners

Final Cryomodule and Load Lock System will be Assembled and Delivered by MSU

Scope	FRIB	ANL	HZDR	SLAC
Overall Project Management and Coordination	✓			
SRF Component and Cryomodule Design	✓	✓		
Magnet Package Design and Testing	✓			
Cathode Stalk Design, Fabrication, RF/DC Testing	✓	✓		
Cathode, Load-lock, Insertion/Transport Design			✓	
Cathode Stalk Particulate Testing			✓	
Cryomodule Major Component Procurement and Assembly	✓			
Load-Lock Major Component Procurement and Assembly	✓			
Cavity Processing and Cold Testing	✓	✓		
Integrated Cavity Test (Tuner/FPC)		✓		
Cavity Bunker Test	✓			
Beam Dynamics	✓	✓		✓



Facility for Rare Isotope Beams
 U.S. Department of Energy Office of Science
 Michigan State University

Challenges and Lessons Learned from Existing Systems

Challenge	Design/Processing/Validation Impact
Field Emission Limits Performance and Produces Dark Current	<ul style="list-style-type: none"> • Four Rinse Ports • Make Cathode System as Clean as Possible • Make FPC Adjustable <ul style="list-style-type: none"> ▪ High Peak Power Pulsed Processing • Plasma Processing if Needed
Multipacting Limits Performance	<ul style="list-style-type: none"> • DC Dias for Cathode Stalk and FPC • Design Systems for MP Avoidance • Apply FRIB Conditioning Experience
SRF Auxiliaries: Couplers and Tuners are Critical Elements	<ul style="list-style-type: none"> • Existing Gun Projects Developed Unique Solutions <ul style="list-style-type: none"> ▪ Dedicated Development • Adapt Proven Technology where Possible
Cathode and RF Choke Critical Performance	<ul style="list-style-type: none"> • Extra RF Pickup in Choke • Sub-System Testing • Iteration as Needed
FPC on Beam Port: Complex System and Downstream Focusing	<ul style="list-style-type: none"> • Separate Off-Axis Port for FPC
RF Pickup on Beam Port Results in Systematic RF Amplitude Error	<ul style="list-style-type: none"> • Pickup Loop in Rinse Port

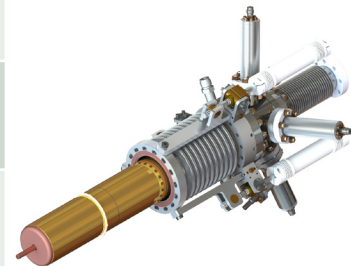
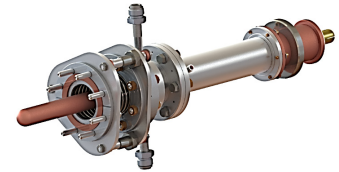
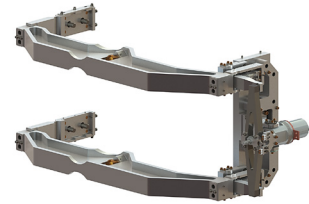

FRIB Cryomodule Road Map

Modular Design to Used on All FRIB Cryomodule Types

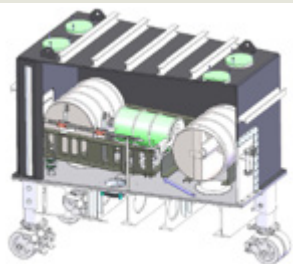

ETCM, tests completed in 2013

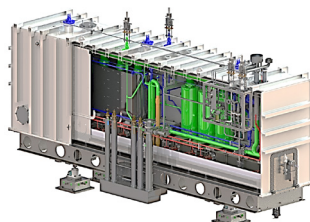

FRIB $\beta=0.085$ QWR
design complete 2015

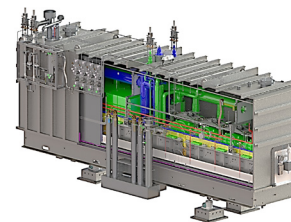

FRIB $\beta=0.53$ HWR
design complete 2016

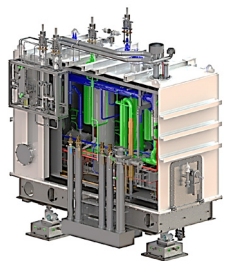

FRIB $\beta=0.041$ QWR
design complete in 2016

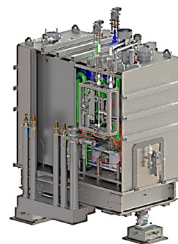

FRIB $\beta=0.085$ QWR Rebuncher
design complete in 2016

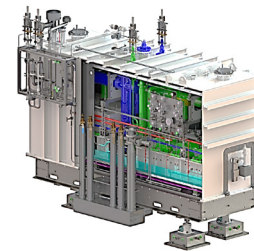

FRIB $\beta=0.29$ HWR
design complete 2017

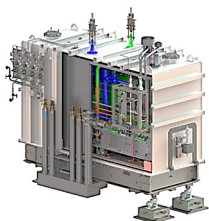

FRIB $\beta=0.53$ HWR Rebuncher
design complete 2017

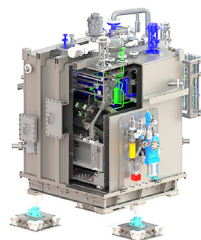

SRF Gun QWR
design complete 2022

Jefferson Lab

Jefferson Lab

3D CAD SRF Gun Cryomodule Overview

Cryomodule Dimensions (in)					
Property	$\beta=0.041$	$\beta=0.085$	$\beta=0.29$	$\beta=0.53$	SRF Gun
Length	117	236	143	230	62
Width	61	60	60	60	72
Height	114	114	109	107	102

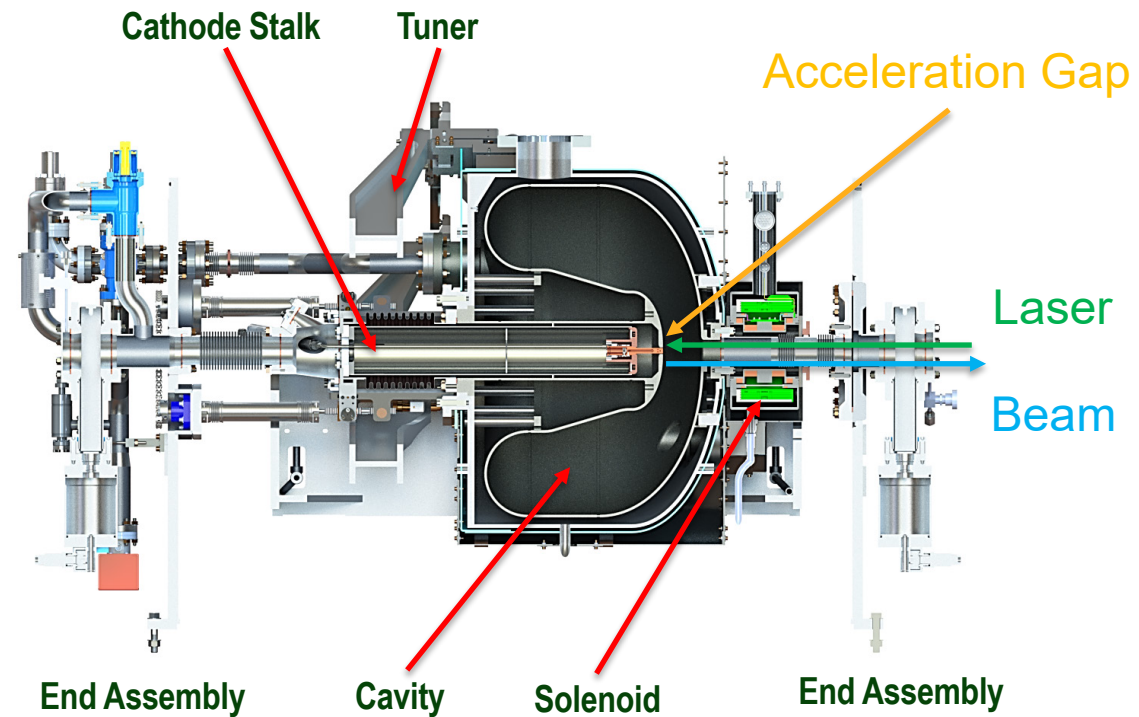
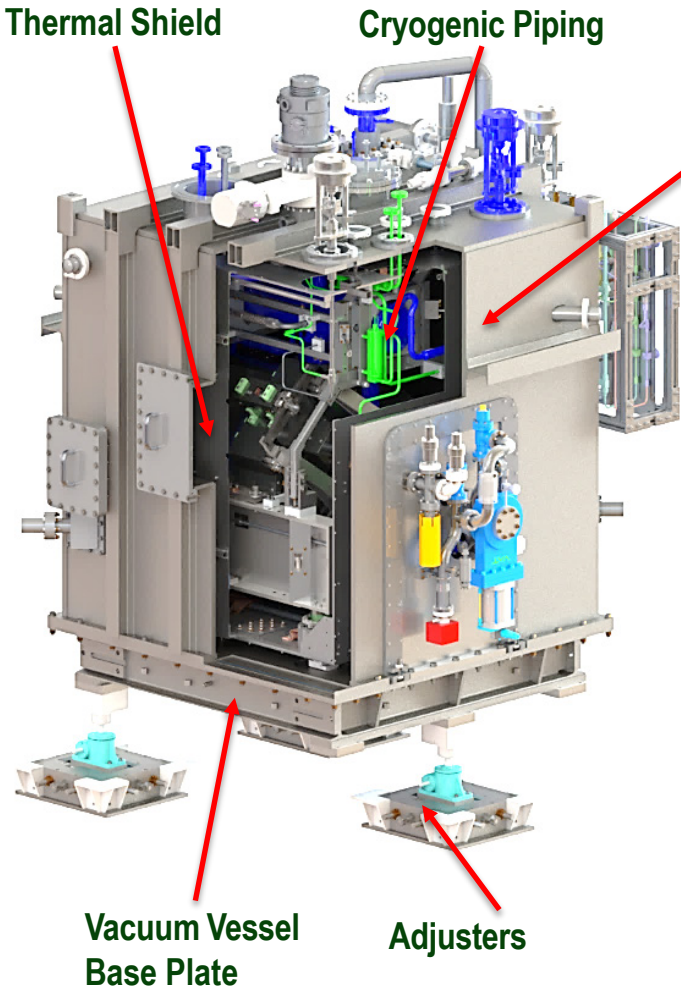

SRF Gun Cryomodule Design: Cavity

Cavity Parameters	Value
f ₀ (MHz)	185.75
Geometry Factor (Ω)	84.5
Quality factor Q ₀ @ 4.4 K ⁽¹⁾	1.3x10 ⁹
r/Q (Ω)	131
E _c (MV/m)	30
Stored Energy U (J)	21.4
B _{peak} (mT)	52.9
E _{peak} (MV/m) with cathode	33.7
Cavity wall dissipation power P _w ⁽¹⁾ (W)	20
Gap Voltage V ₀ ⁽²⁾ (MV)	1.81
Accelerating voltage V _{acc} (β=1) (MV)	1.80
df/dP (Hz/Torr)	-3.95
df/dx (kHz/mm)	-435
dF/dx (kN/mm)	44.6
Tuning Force: 60kHz, 15 psi, 4K (kN)	8.4
LFD (Hz/J)	-29
Modes 1-4 (Hz)	157, 182, 191, 227

(1) Estimated 4.4 K R_s is 66 nΩ, no 120 °C baking case.

(2) $V_0 = \int E_z(z)dz$, geometric shunt impedance = $\frac{V_0^2 P_w}{P_w \omega_0 U}$

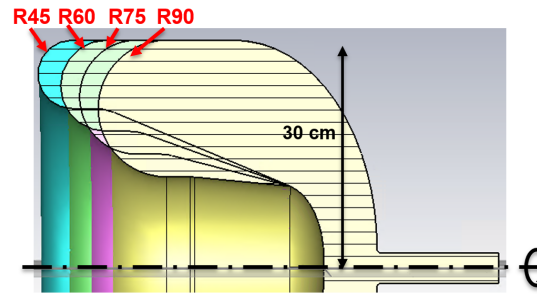

Cavity Shape Optimization

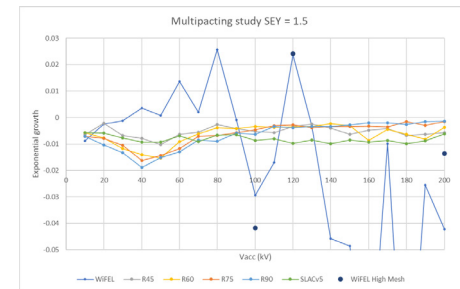

Multipacting Study

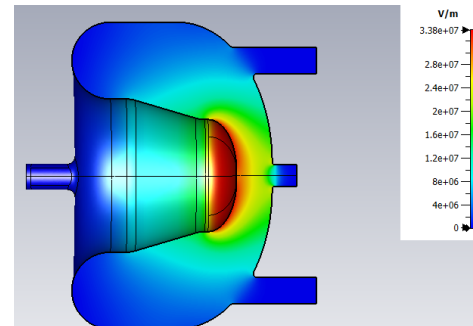

E-field at E_c = 30 MV/m, E_{peak} = 33.7 MV/m

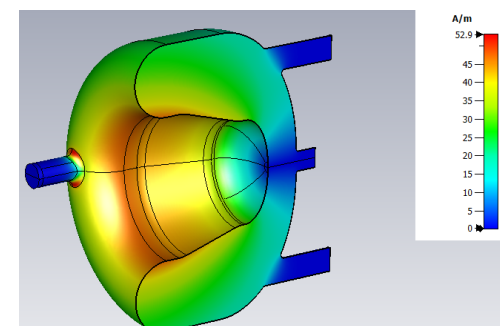

B-field at E_c = 30 MV/m, B_{peak} = 52.9 mT



Cavity Mechanical Model

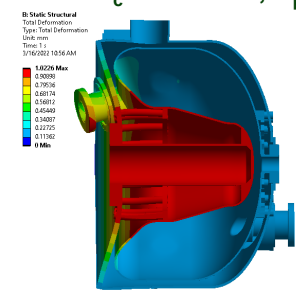

df/dx = -435 kHz/mm

SRF Gun Cryomodule Design: Cavity

Design to be compatible with BPVC Sec VIII, Div.2: Part 5 Limit Load

Temperature	Loads	Description	Load Factor	Limit Load
300 K	Gravity	Warm Pressurization	1.5(P2+Gravity)	Converges
	P2=0.227 MPa			
	P1=P3=0 MPa			
300 K	Gravity	Warm Pressurization + Tuner Compression	1.3(P2+Gravity+T)	Converges
	P2=0.227 MPa			
	P1=P3=0 MPa			
	T=0.14 mm			
4 K	Gravity	Cold Pressurization	1.5(P2+Gravity)	Converges
	P2=0.41 MPa			
	P1=P3=0 MPa			
4 K	Gravity	Cold Pressurization + Tuner Compression	1.3(P2+Gravity+T)	Converges
	P2=0.41 MPa			
	P1=P3=0 MPa			
	T=0.14 mm			

Cavity Mesh

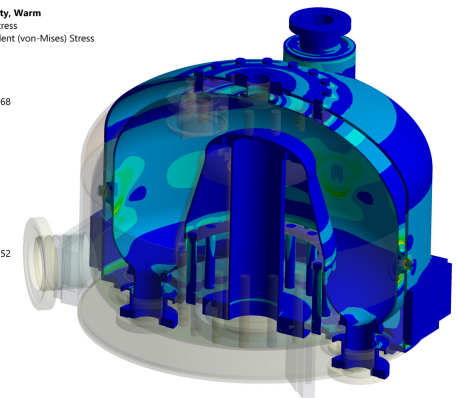
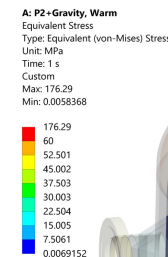

Cavity Stress Analysis Results

SRF Gun Cryomodule Design: Fundamental Power Coupler

■ Cavity Design for FPC

- Low-field multipacting mitigated by design
- Four access ports for electro-polishing (EP) and high-pressure water rinsing (HPR)
- Off-beam-axis FPC port to reduce impacts of potential particulate contamination on cavity operation
- Mechanical design to support stable resonance control at 4 K [df/dP, Lorentz Force Detuning (LFD), mechanical modes]

■ FPC

- ANL 162.5 MHz FPC design, validated with the PIP-II HWRs
 - » Designed for assembly without particulate contamination

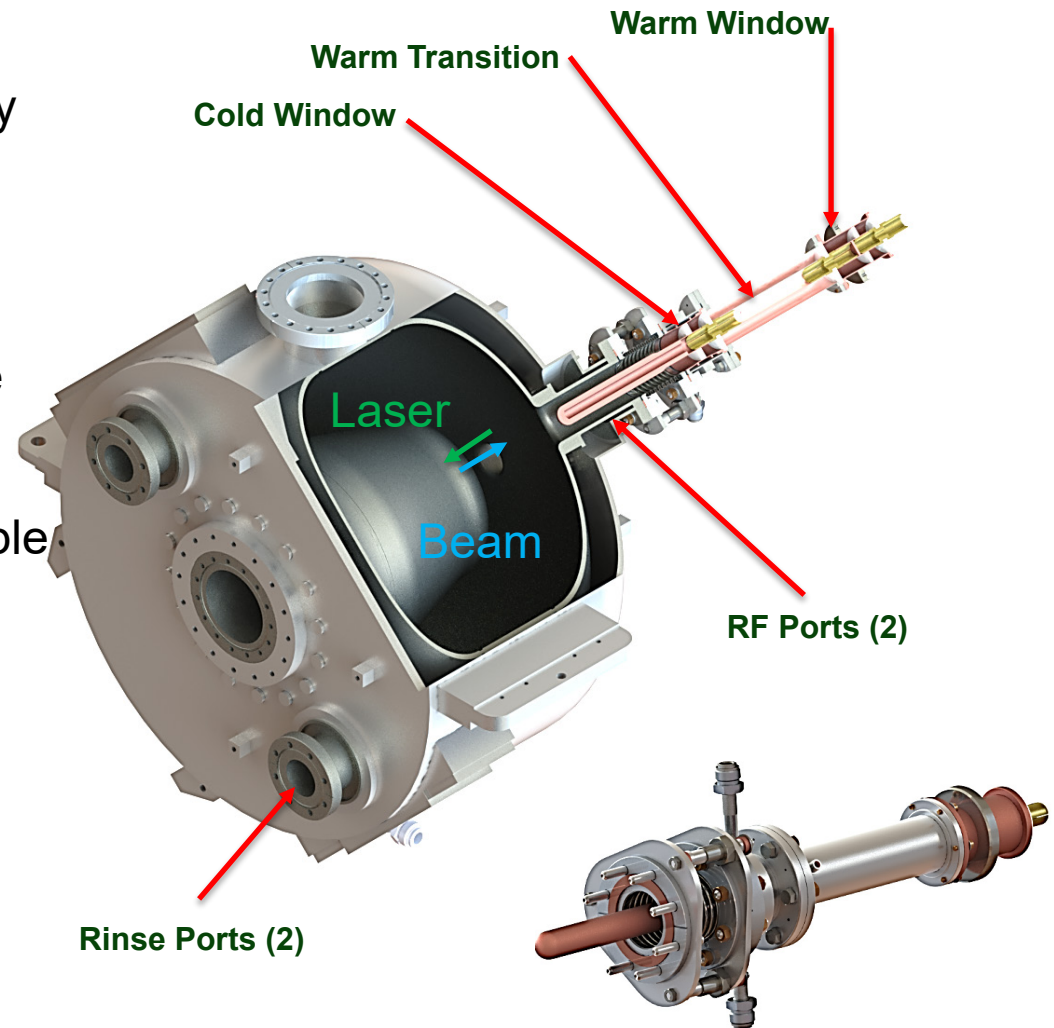

SRF Gun Cryomodule Design: Tuner

- FNAL tuner design validated on PIP-II-SSR1
- Unidirectional tuning to the cathode port
- Design includes a stepper motor based slow tuner and Piezo actuator based fast tuner
 - Stepper: Pythron VSS 52.200.1.2
 - Piezo: PI P-844.20
 - » Fast tuning Piezo actuators have resolution < 1 Hz

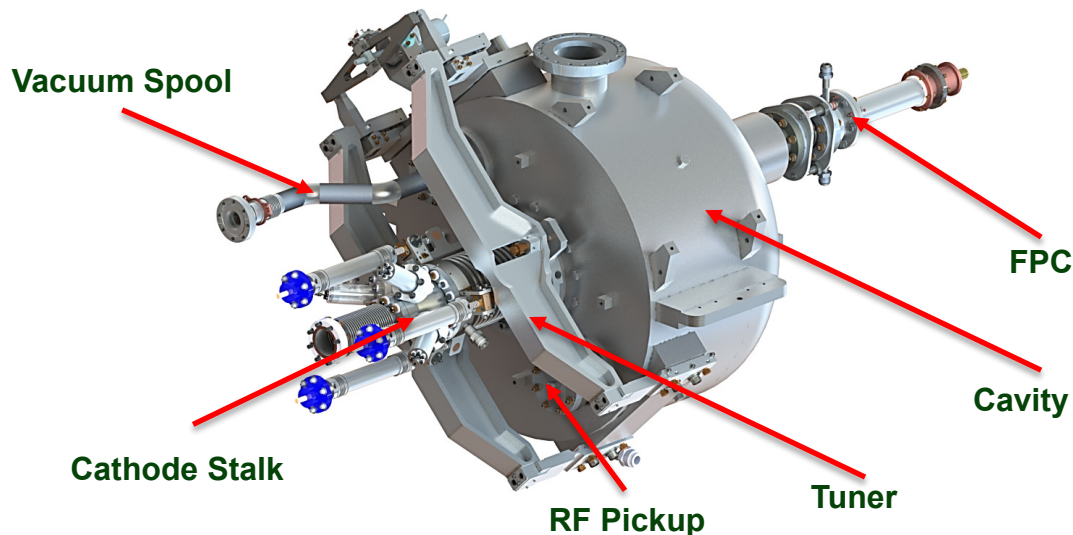

Parameter	Value	Unit
Stepper coarse tuning range	-60 kHz	
Tuning sensitivity	-435 kHz/mm	
Cavity stiffness	61 kN/mm	
Piezo mechanical advantage	2.22	
Stepper mechanical advantage	9.27	
Max tuning displacement	0.138 mm	
Max tuning force	8.4 kN	
Force on a piezo out of two	1.9 kN	
Force on the stepper	0.91 kN	
Stepper planetary gear ratio	50	
Stepper resolution (motor)	200 rev/step	
Stepper shaft pitch	1 mm/rev	
Stepper linear resolution (motor)	0.1 μ m/step	
Stepper linear resolution (cavity)	0.011 μ m/step	
Stepper tuning resolution	4.7 Hz/step	
Piezo travel range (piezo)	20 μ m	
Piezo travel range (cavity)	9.0 μ m	
Piezo fine tuning range	-3.9 kHz	
Piezo resolution (piezo)	0.3 nm/mV	
Piezo resolution (piezo)	0.14 nm/mV	
Piezo tuning resolution	0.06 Hz/mV	

SRF Gun Cryomodule Design: Solenoid

- The emittance compensation solenoid will be utilized for the compensation of adverse space charge effects on the emittance of the electron beam
- The solenoid contains two sets of windings that can be independently powered in addition to bucking coils to minimize the fringe field at the resonator surface
- The package also contains dipole and quadrupole coils to correct field errors due to misalignment and fabrication imperfections
- Adjustors are built into the solenoid package mounts to allow for adjustment within ± 0.2 mm

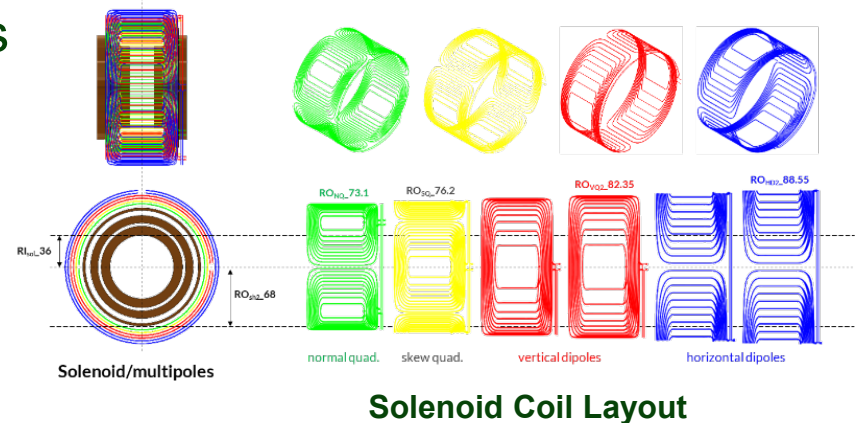
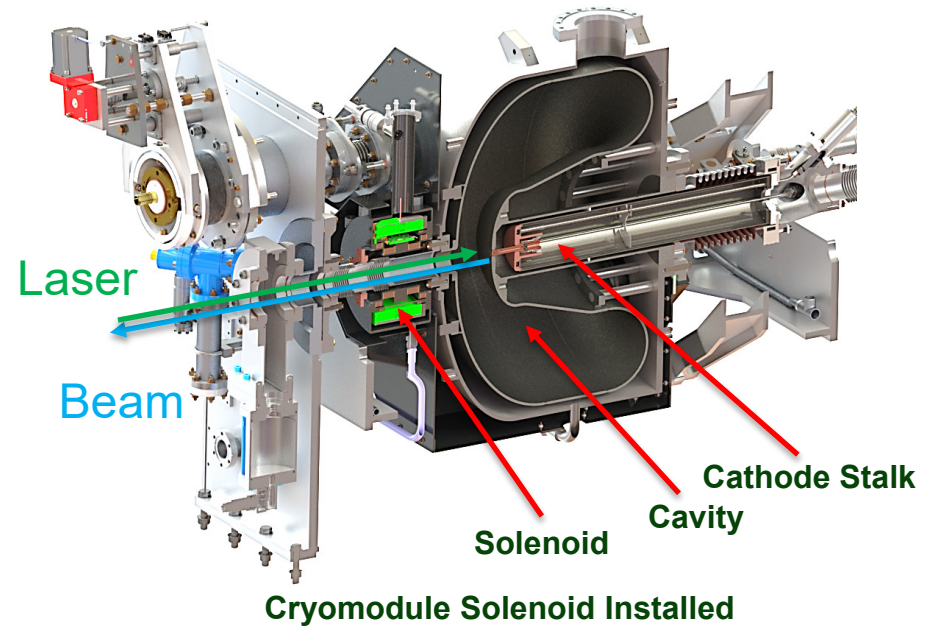

SRF Gun Cryomodule Design: Cathode Stalk

- Precision alignment control of the cathode position
- Bias the coaxial structure of the cathode and cathode stalk up to 5 kV DC to prevent multipacting
- Temperature adjustability of the cathode which can be utilized to improve cathode performance
- Prevent field emission by providing a particle free cathode exchange

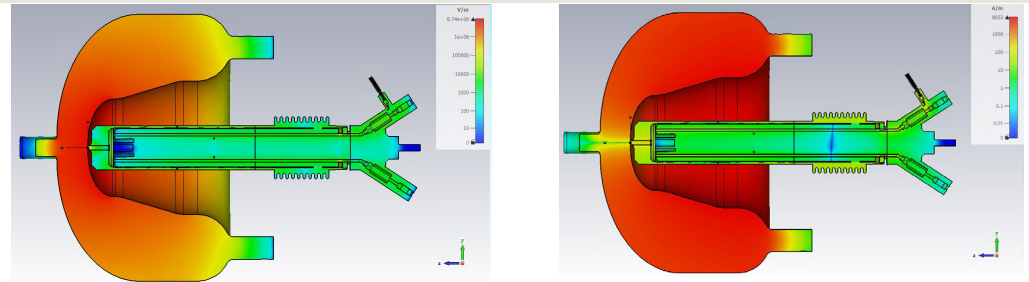

E Field

H Field

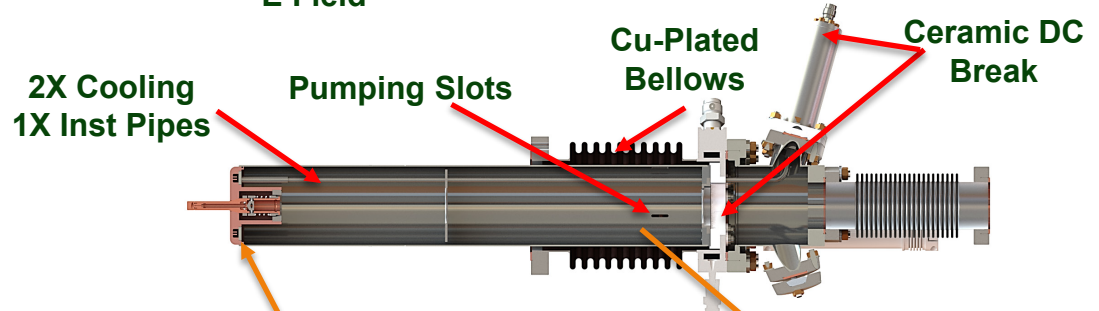

Gold-Copper Plating

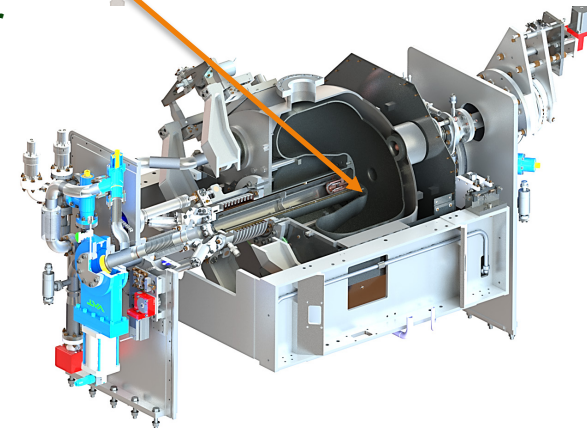
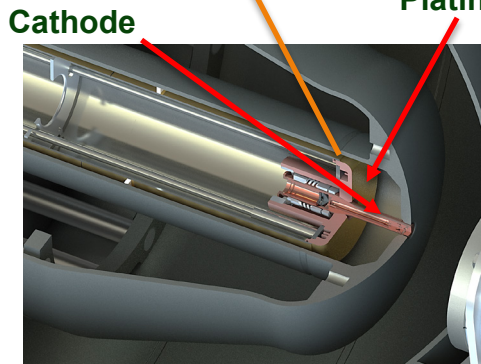

SRF Gun Cryomodule Design: Alignment and Fiducialization Plan

- Cathode plug aperture data transferred to HV tabs fiducials
- Cavity placed on alignment rails
- Definition of beamline established based on cavity alignment
- Solenoid adjusts to match cavity beamline
 - If the solenoid magnetic center deviates from the theoretical center by more than $\pm 0.2\text{mm}$ and $\pm 5\text{ mrad}$ at $z=0$, adjustment can be made using the solenoid adjustment system
- Thermal offsets accounted for in placements
- End assemblies evaluated to cavity beamline
- Beamline data transferred to cryomodule baseplate

2 Alignment and Fiducialization Strategy

2.1 SRF Gun Cavity

2.1.1 The cathode aperture placement relative to the beamport is determined by the fabrication of the cavity in accordance to print L10803-MDE-0105-0000.

2.1.2 The clocking of the FPC port is determined by the fabrication of the cavity in accordance to print L10803-MDE-0105-0000.

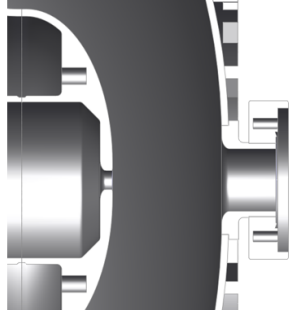

Figure 1: Cathode Aperture Alignment to Beamport

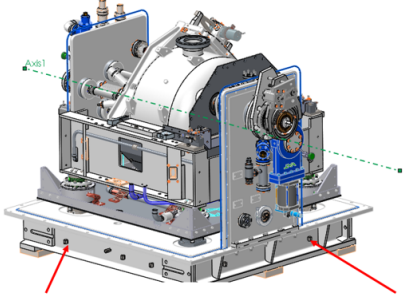

Figure 10: SRF Gun Cryomodule Baseplate Monuments

2.8 Cryomodule Assembly

2.8.1 The baseplate fiducials now contain the complete information of the component alignment and will be used to align the cryomodule.

2.8.2 Using the orthogonal adjusters below the cryomodule, adjust the cryomodule beamline location to the desired location.

SRF Gun Cryomodule Design: Thermal Contraction and Alignment

- The fixed post and “fixed” side of the cavity are coincident and develop a “fixed” side for all thermal contraction
- The cavity and solenoid independently transversely contract from the “contraction” side to the “fixed” side
 - The contraction is calculated and offset by the cavity and solenoid placement

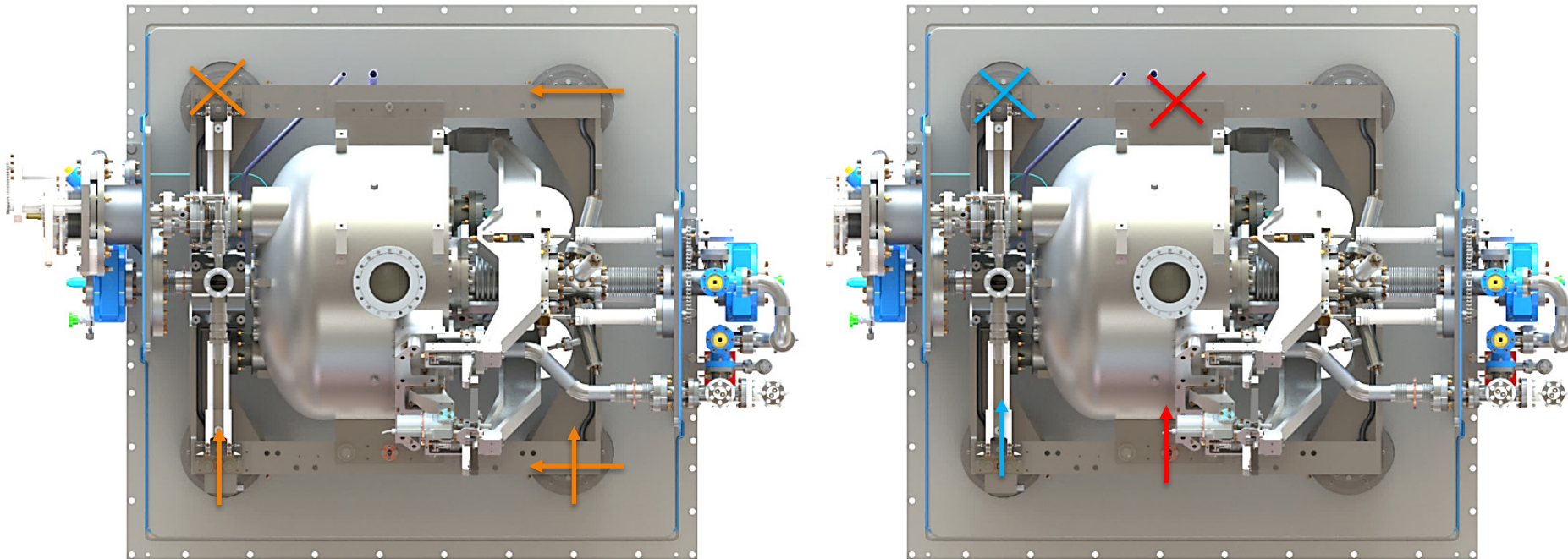

SRF Gun Design: Coldmass Integration

End Assembly

Tuner

End Assembly

Magnetic Shield

Thermal Shield

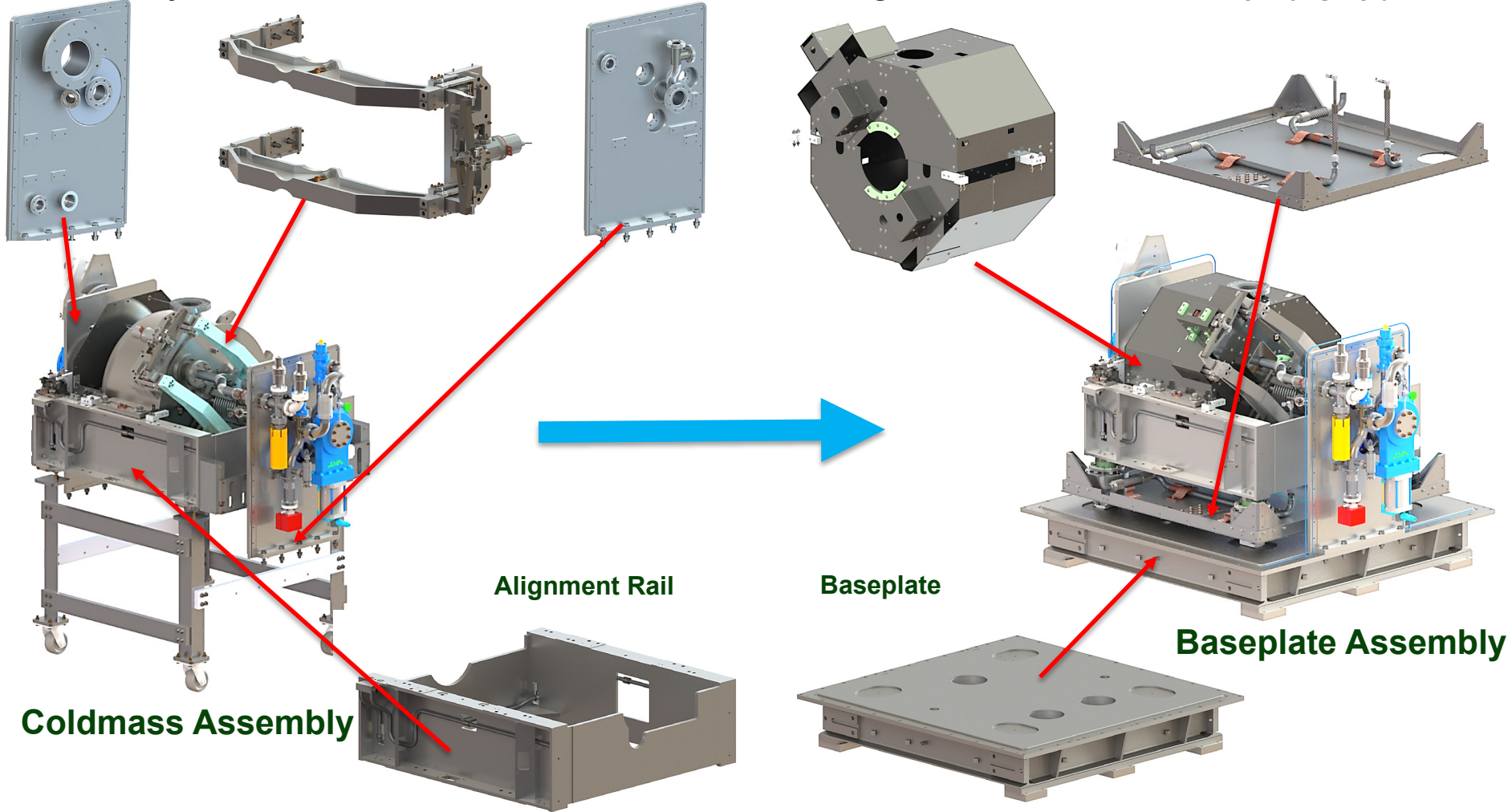

Coldmass Assembly

Alignment Rail

Baseplate

Baseplate Assembly

SRF Gun Design: Cryogenic Installation

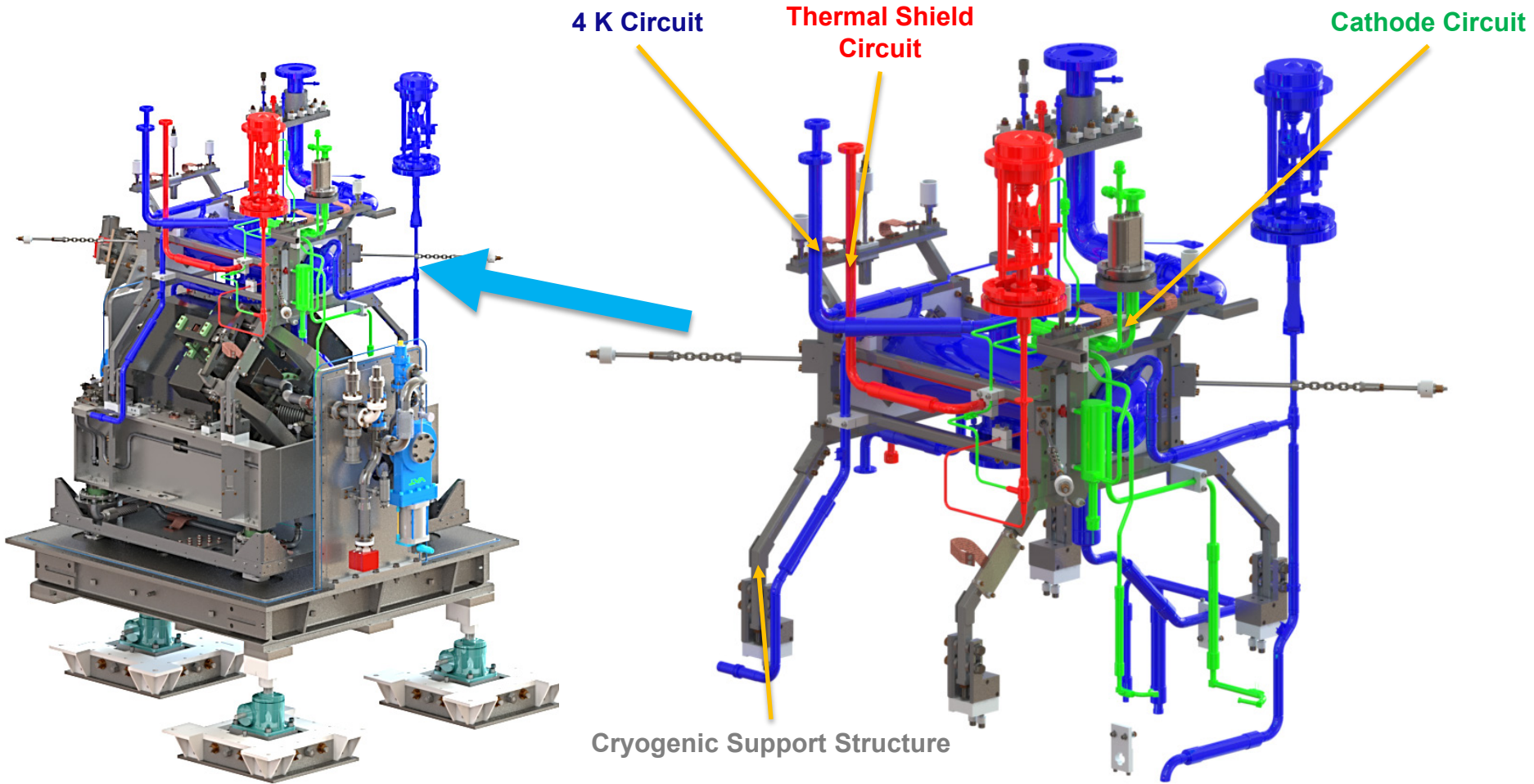

Cryomodule Cryogenic Installation

Cryogenics System

SRF Gun Design: Cryomodule Integration

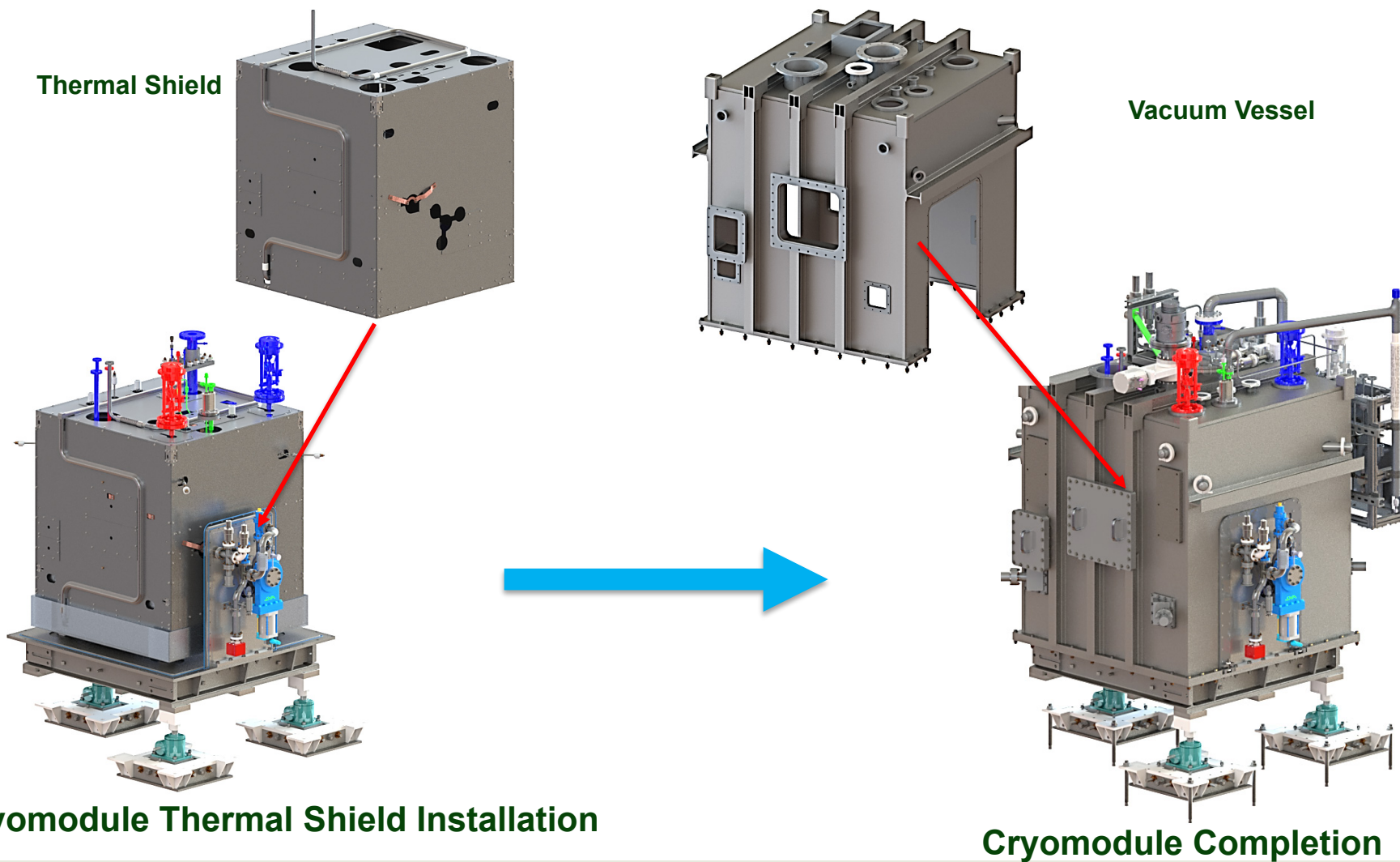

Cryomodule Thermal Shield Installation

Cryomodule Completion

SRF Gun Cryomodule Fabrication Plans/Status

Part number	Description	Plan	Delivery Date (Planned)	Status
L10803-MDE-0303-0000	SRF GUN LOAD LOCK SYSTEM	Procurement	Oct 2023	After Cathode FDR
L10803-MDE-0304-0000	SRF GUN CATHODE STALK	Procurement	Sep 2023	Started the 2 nd cathode stalk based on RF testing
L10803-MDE-0193-0000	SRF GUN CRYOMODULE STANDS	Procurement	May 2023	Test Assembly at Supplier
L10803-MDE-0313-1000	SRF GUN CRYOMODULE SHIPPING FRAME	Procurement	May 2023	Shipment Ready
L10803-MDE-0266-0000	SRF GUN CRYOGENICS	Procurement	July 2023	In-House Fabrication
L10803-MDE-0301-0000	SRF GUN UPPER COLDMASS MLI	Procurement	Mar 2023	Received
L10803-MDE-0275-0000	SRF GUN THERMAL SHIELD	Procurement	May 2023	Shipment Ready
L10803-MDE-0302-0000	SRF GUN UPPER THERMAL SHIELD MLI	Procurement	Mar 2023	Received
L10803-MDE-0260-0000	SRF GUN VACUUM VESSEL COVER	Procurement	May 2023	Inspection Complete/Painting
L10803-MDE-0296-0000	SRF GUN SEAL PLATE	Procurement	Nov 2022	Shipment Ready
L10803-MDE-0299-0000	SRF GUN LOWER COLDMASS MLI	Procurement	Mar 2023	Received
L10803-MDE-0300-0000	SRF GUN LOWER THERMAL SHIELD MLI	Procurement	Mar 2023	Received
L10803-MDE-0253-0000	SRF GUN VACUUM VESSEL BASEPLATE	Procurement	May 2023	Inspection Complete/Painting
L10803-MDE-0278-0000	SRF GUN ALIGNMENT POST	Self-perform	Sep 2023	In-House Fabrication
L10803-MDE-0259-0000	SRF GUN TUNER	Procurement	Aug 2022	Received
L10803-MDE-0261-0000	SRF GUN MAGNETIC SHIELD	Procurement	May 2023	Received
L10803-MDE-0171-0000	SRF GUN ALIGNMENT RAIL	Procurement	May 2023	Shipment Ready
L10803-MDE-0246-0000	SRF GUN END ASSEMBLY	Procurement	May 2023	Shipment Ready
L10803-MDE-0146-0000	SRF GUN FUNDAMENTAL POWER COUPLER	Procurement	Aug 2022	Received 1 st article - 2 nd /3 rd NCR & rework at vendor
L10803-MDE-0174-0000	SRF PICKUP ANTENNA	Procurement	Jul 2022	Received
VENDOR PART	PIEZO AND STEPPER MOTOR	Procurement	June 2023	Partial Received
VENDOR PART	CONTROL VALVES	Procurement	May 2023	Received
VENDOR PART	GATEVALVE	Procurement	June 2023	Contracted
VENDOR PART	INSTRUMENTATION AND FEEDTHRU	Procurement	Mar 2022	Received
MATERIAL	NB & NBTI	Long Lead	Apr 2022	Received



SRF Gun Cryomodule Fabrication Plans/Status- Coldmass



SRF Cavity

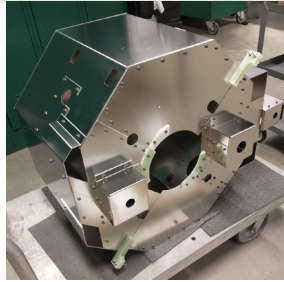

Magnetic Shield



Fundamental Power Coupler

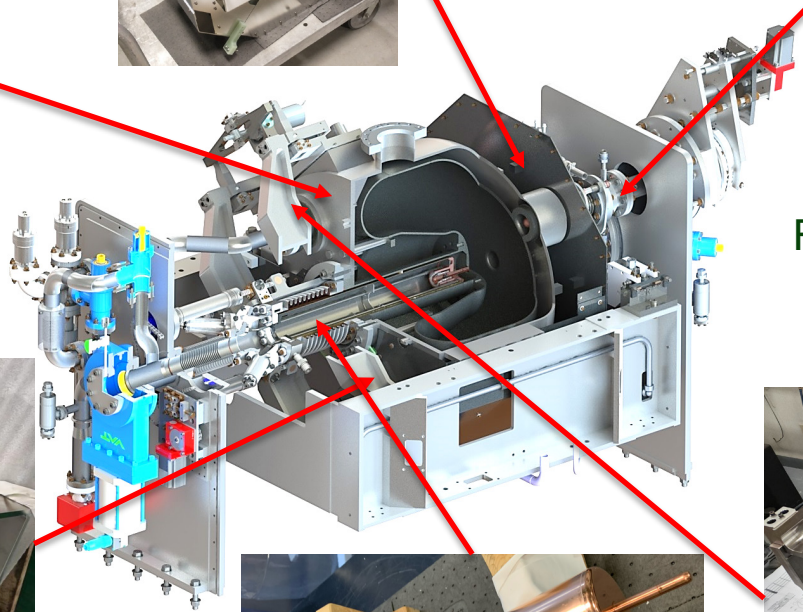

Alignment Rail

Full Stress Relieve to Minimize Distortion During Cool-down
Reset To Austenitic State (Min. Permeability)



Cathode Stalk

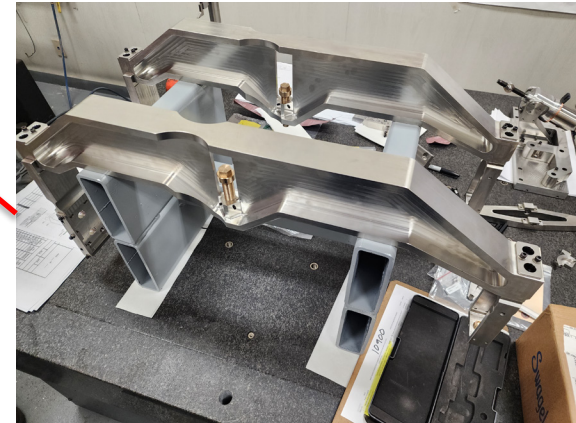

Tuner

SRF Gun Cryomodule Fabrication Plans/Status- Cryomodule

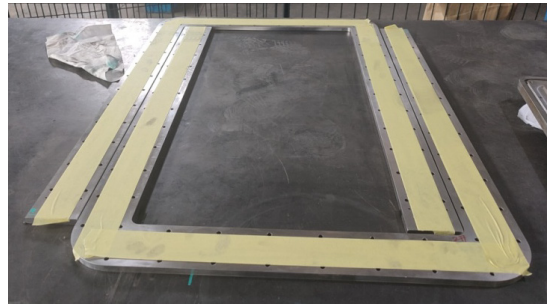

Vacuum Vessel Seal Plate

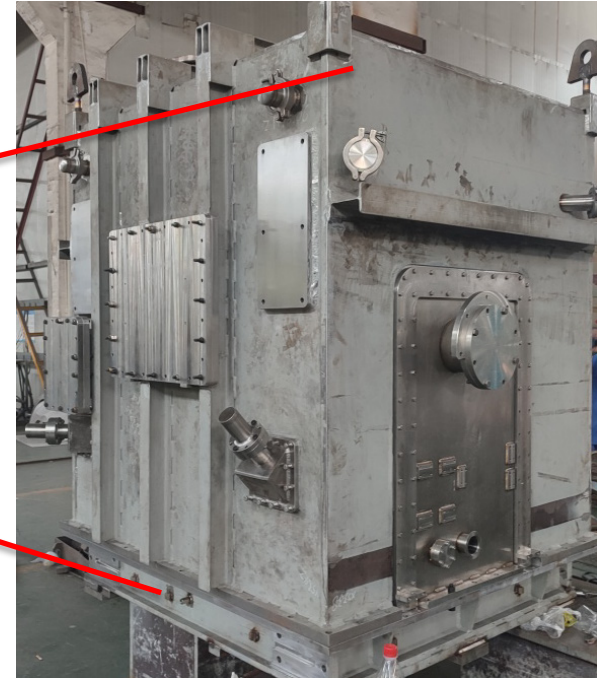
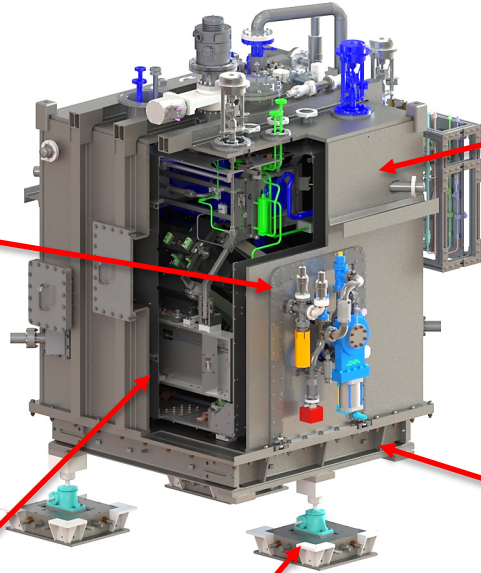

Vacuum Vessel Baseplate & Cover



Thermal Shield



Adjuster Components



3 Way O-ring
Separated Cavity/Cryomodule Isolation Vacuum

SRF Gun Cryomodule Testing Plans

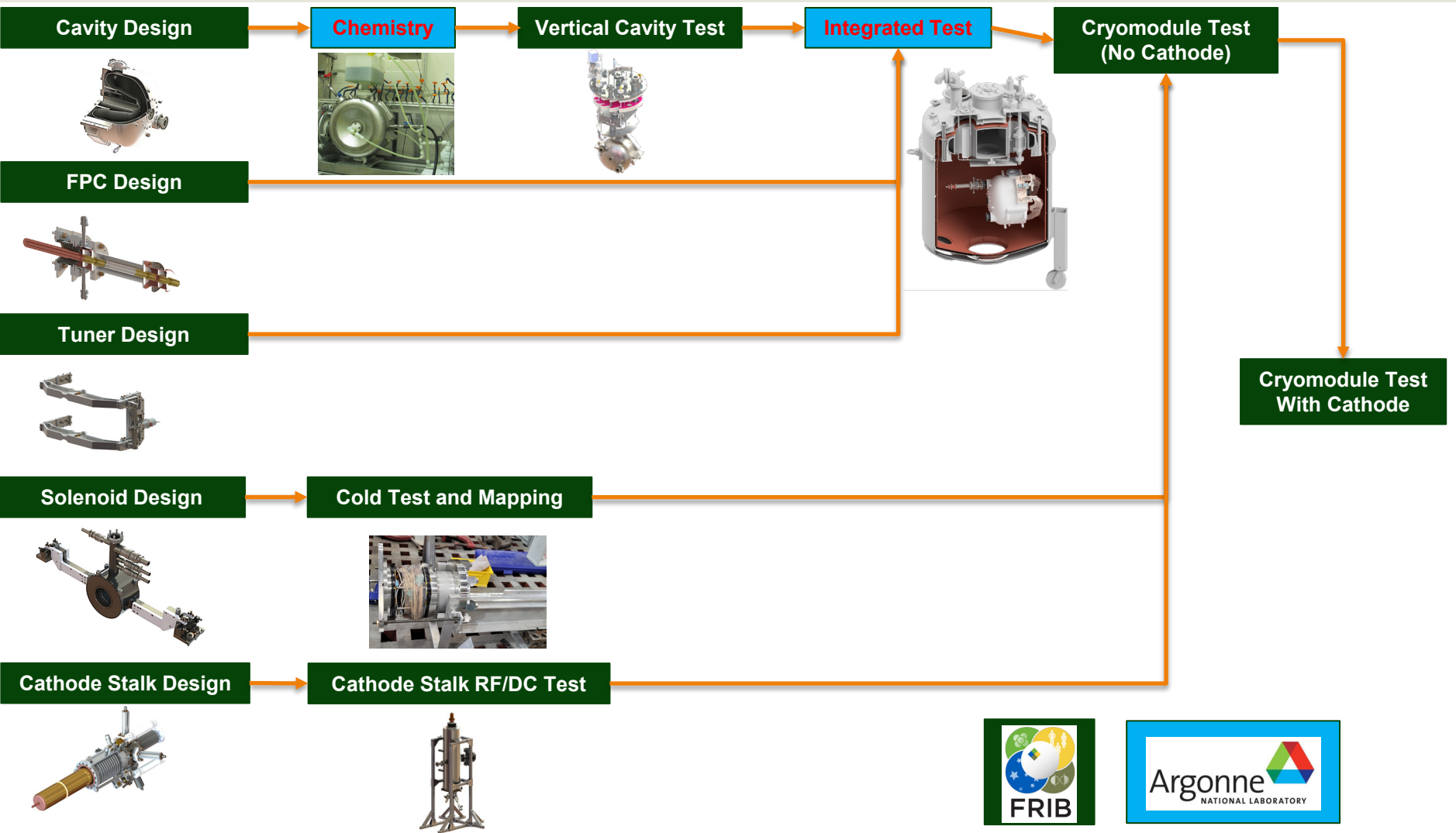

Summary and Path Forward

- SRF Gun cryomodule design has been completed to the performance goals/requirements
- Cryomodule component fabrication is ongoing and progressing smoothly
- Validation plans for critical systems are established and where possible proceeding
- The first cavity will be tested in the second half of 2023

