

COMMISSIONING OF A NEW SAMPLE TEST CAVITY FOR RAPID RF CHARACTERIZATION OF SRF MATERIALS

S. Keckert*, F. Kramer, O. Kugeler, J. Knobloch¹, Helmholtz-Zentrum Berlin, Berlin, Germany
¹ also at University of Siegen, Siegen, Germany

Abstract

RaSTA, the Rapid Superconductor Test Apparatus, is a new sample test cavity that is currently being commissioned at HZB. It uses the established QPR sample geometry but with a much smaller cylindrical cavity operating in the TM_{020} mode at 4.8 GHz. Its compact design allows for smaller cryogenic test stands and reduced turnaround time, enabling iterative measurement campaigns for thin film R&D. Using the same calorimetric measurement technique as known from the QPR allows direct measurements of the residual resistance. We report first prototype results obtained from a niobium sample that demonstrate the capabilities of the system.

INTRODUCTION

Characterizing the RF properties of samples – especially by measuring the surface resistance (R_S) – is essential for systematic R&D on superconducting thin films and multilayer structures for SRF applications. The quadrupole resonators (QPR) at CERN [1] and HZB [2] are well suited for this and allow for high-precision measurements of R_S as a function of temperature and RF field at three frequencies. The effort for each measurement run is quite high: A quick test with only few days of cold testing requires at minimum two weeks including sample preparation, mounting and warmup of the cryostat. This is acceptable for characterizing samples in-depth from optimized preparation techniques. However, most of the time procedures and coating recipes have to be developed or optimized iteratively with a large number of samples. In that case, ‘yes/no’ statements or a monitoring of relative changes are more relevant. For that, a sample test cavity with higher throughput at reduced capabilities is highly desirable. The Rapid Superconductor Test Apparatus (RaSTA) is meant to be exactly this device. Its main features are:

- Full compatibility to the HZB QPR by using the same sample geometry, allowing pre-selection of samples, cross-calibration and direct comparison of both setups.
- Calorimetric measurement of R_S as a function of temperature at a frequency that is low enough to allow for a direct analysis of the residual resistance (R_{res}).
- Reduced turnaround time, aiming at testing more than one sample per week

The last point of reduced turnaround time is closely connected to the entire infrastructure and not (only) a property of the cavity itself. In our case, this goal can be achieved by

- Operation without radiation protection measures by limiting the maximum RF voltage in the cavity to few kV.
- Reduced size of the cavity to fit into a small and stand-alone cryostat with fast cycling times.

In the following, we introduce the design of RaSTA and discuss first results from the commissioning of a prototype cavity. The design is patented under DE 10 2021 123 261 [3].

DESIGN

For a calorimetric measurement of R_S on QPR samples a cavity has been found such, that (a) a sufficiently strong RF magnetic field is present on the sample surface but not on its cylindrical sidewalls and (b) the sample can be mounted into the cavity with sufficient thermal decoupling. Geometric boundary conditions are the sample diameter of 75 mm and its height of 85.5 mm when mounted into a CF100 flange. For further details of QPR samples see Ref. [2].

RF Design

Inspired by the mode spectrum of a pillbox cavity, the TM_{020} mode was chosen as the operating mode for the RaSTA cavity. This mode features a zero-crossing of the magnetic field which allows for a coaxial gap to insert a QPR sample into the cavity. The resonant frequency (i.e. the cavity radius) is chosen such, that the zero-crossing fits to the sample diameter of 75 mm. The obtained value of 4.8 GHz leads to much higher R_{BCS} compared to QPR measurements but when operating at 1.5 K, R_{BCS} of approx. 10 n Ω for niobium still allows for direct measurements of R_{res} . For higher- T_c materials the situation is more relaxed.

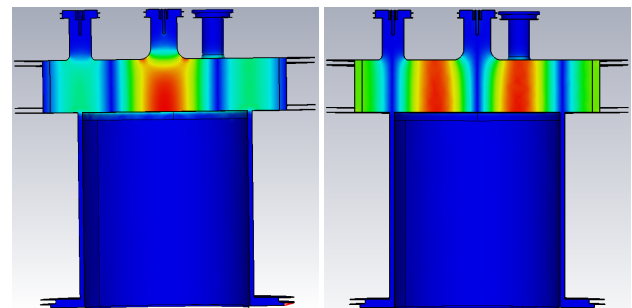

Figure 1: Simulated maps of electric (left) and magnetic (right) RF field for the operational TM_{020} mode at 4.8 GHz.

Given by the TM_{020} mode’s symmetry the height of the cavity can be made very small, for technical reasons a value of 23.7 mm was chosen. This comes with the advantages

* sebastian.keckert@helmholtz-berlin.de

of a low RF voltage (no radiation protection) and a clean mode spectrum since many modes are pushed to very high frequencies.

The excitation of other modes is further suppressed by using two electrical couplers at specific locations: 1) A critically coupled input antenna is mounted at the cavity center and 2) a weakly coupled pickup antenna is placed at the location of the coaxial gap where a second maximum of the RF electric field in the TM_{020} mode is located. A third port at the cavity top is used for vacuum pumping.

Simulated maps of the RF fields on a cross-section of the cavity are shown in Fig. 1.

Mechanical Design

The first prototype was designed to be as simple as possible to test the basic principles without long lead times and complex manufacturing. For that reason, it was decided to use stainless steel flanges that were coated with niobium on all RF surfaces. Figure 2 shows a CAD cross-section of the assembled cavity. The center cavity flange is turned from a double-sided CF125 blank flange, the top part is another blank flange with three CF16 ports for antennas and vacuum pumping. For the coaxial part a custom CF125/CF100 reducer was made to mimic the bottom part of the QPR. That way, sample, diagnostics and bottom feedthrough could be taken from the existing QPR setup.

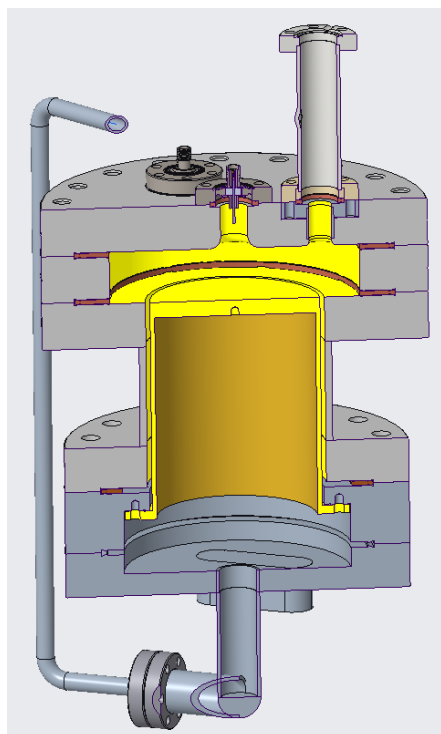

Figure 2: CAD cross-section of the RaSTA prototype cavity. Stainless steel CF flanges were niobium coated on all RF surfaces (yellow), the QPR sample is made from bulk niobium.

The demountability of all cavity parts enabled niobium coating at University of Siegen with the existing infrastruc-

ture. Niobium films with thickness of 16 μm were deposited by HiPIMS using the successful procedure developed for QPR sample adapter flanges [4].

Special care needed to be taken for the copper gaskets sealing the CF125 parts of the cavity. The inner diameter of standard gaskets is larger than the cavity's diameter and the gap between flange surfaces and gaskets would lead to dissipative field enhancement. This was mitigated by using custom gaskets with inner diameter identical to the one of the cavity. Furthermore, several RF contacts at the inner edges of the gaskets seal off the cylindrical cavity. Evacuation of the dead volume between RF contact and CF knife edge is ensured by small gaps intercepting the RF contacts. Experience showed that sufficient electrical contact can only be obtained when using freshly annealed soft copper and a maximum torque larger than 25 Nm. Up to now, no loss of electrical contact was observed when cooling down the cavity. The impact of normal conducting copper gaskets on the RF performance of the cavity is discussed below.

MEASUREMENT SETUP

Main purpose of the RaSTA cavity is to measure the R_S of a sample. By using QPR samples and the identical lower structure as for the QPR, the same calorimetric measurement technique applies: A central heater and several calibrated Cernox temperature sensors are connected to the bottom surface of the sample. The heater is used to heat up the sample to a temperature of interest and the required heater power is recorded. After switching on the RF power, a PID control loop reduces the heater power to stabilize the sample temperature again. The corresponding difference in heater power equals the RF dissipation and can be used to calculate the sample R_S . Note that both, helium bath and cavity temperature remain unchanged. For details about the measurement technique see Ref. [2].

COMMISSIONING RESULTS

In the normal conducting state, the cavity's quality factor Q_0 is dominated by normal conducting niobium surfaces. 72.4% of the RF losses occur on the cavity coatings, 25.3% on the bulk niobium sample and 2.3% on the copper gaskets. The measured value of 6030 fits well to the simulated one being 6068 and excludes large contact resistance between the individual parts of the cavity and the copper gaskets. During cooldown, the niobium RRR can be estimated from the increase in Q_0 right before the superconducting transition of the cavity. A value of

$$\text{RRR} = \left(\frac{Q_{10\text{K}}}{Q_{\text{RT}}} \right)^2 = \frac{26630^2}{6030^2} = 19.5 \quad (1)$$

is obtained. In the superconducting state, Q_0 is dominated by the two copper gaskets of the cavity. From simulations, a value of $Q_0 = 1.4 \times 10^6$ is expected, assuming copper with RRR 31 or higher, i.e. being in the limit of the anomalous skin effect. Measurements yielded $Q_0 = 3.45 \times 10^5$ which

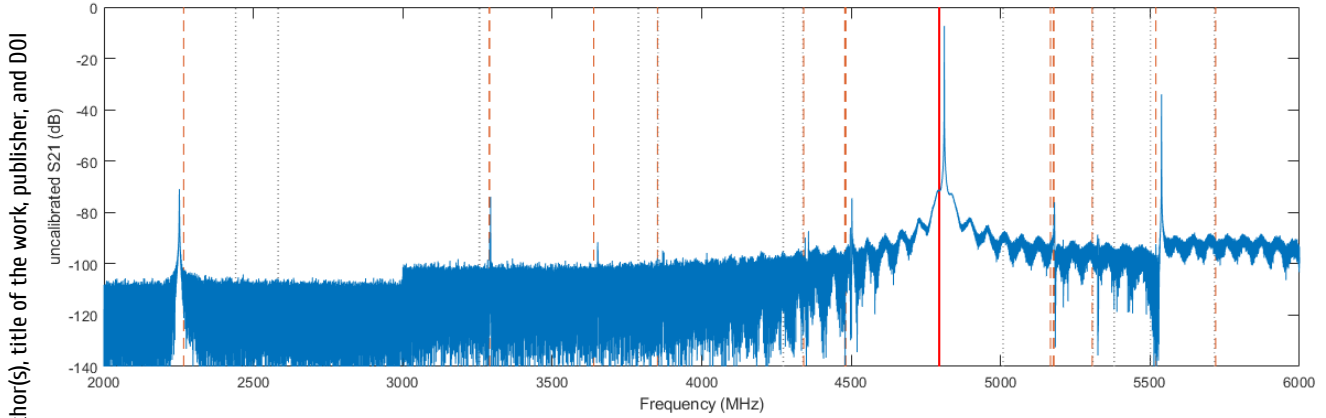

Figure 3: Mode spectrum measured with a VNA at 4 K. Simulation results are shown with vertical lines dashed lines, dotted lines indicate too low coupling to be detected in this measurement. The TM_{020} mode is highlighted by a solid line.

could be caused by low-conductivity copper ($RRR = 1.8$) or due to resistances at the RF contact points.

One reason for the small cavity height was to have only few resonant modes below 6 GHz. Operational experience with the QPR showed that sufficient spectral purity in the neighborhood of modes used for measurements are essential. For RaSTA, there are no other modes within ± 200 MHz. Figure 3 shows the measured and simulated mode spectra in the range of 2 GHz to 6 GHz which are in good agreement. Except for the operational mode at 4.8 GHz all other modes are excited only very weakly (low S_{21}), thanks to the design and positioning of the two antennas.

The mismatch of expected and actual Q_0 of the cavity led to significant under-coupling of the input antenna with $\beta \approx 0.05$, limiting the achievable field level inside the cavity to about 1.4 mT. Nevertheless, this was sufficient to successfully measure the RF dissipation on the sample and to extract values for R_S . Figure 4 shows the measured RF dissipation on the sample vs. forward power travelling to the cavity.

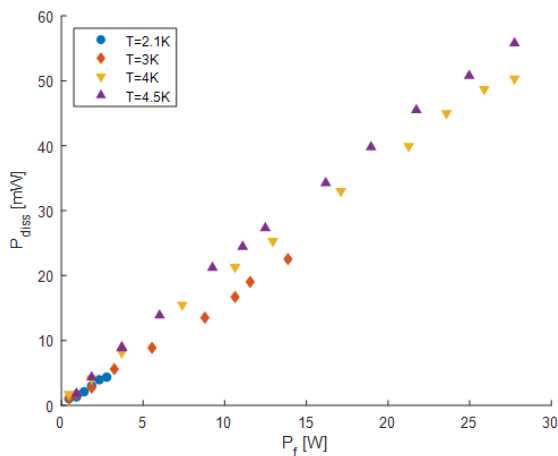

Figure 4: RF dissipation measured on the sample vs. forward power to the cavity at different sample temperatures.

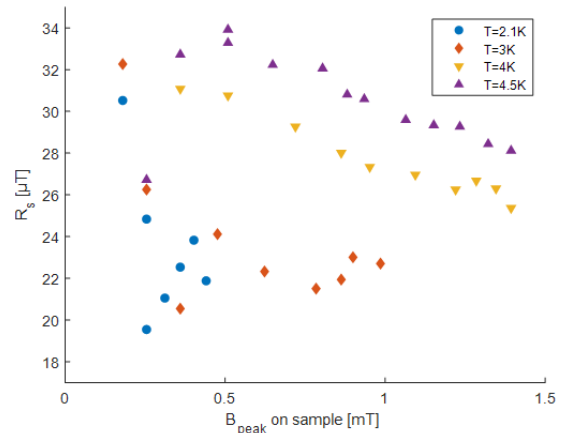

Figure 5: Surface resistance measurement data vs. RF field on sample for different sample temperatures.

Figure 5 shows the final surface resistance data vs. RF field on sample for different temperatures. At the time of the experiment, only a preliminary RF system was available. For that reason, the field level inside the cavity had to be deduced from the amplifier output power which is possible with limited accuracy only. This especially impacted low power levels (i.e. low field levels) that were relevant for measurements at 2.1 K. The substantial scattering of data points – especially at 2.1 K where only low fields could be applied – is due to the large uncertainty of the forward power measurement. This will be improved when further commissioning the RF system. Table 1 summarizes the average values of Fig. 5.

The expected R_S of niobium is calculated using the empirical approximation formula from Ref. [5]

$$R_{BCS} = 2 \times 10^{-4} \frac{1}{T} \left(\frac{f}{1.5 \text{ GHz}} \right)^2 \exp \left(-\frac{17.67}{T} \right). \quad (2)$$

The measurement data indicates a measured offset resistance of about $22 \mu\Omega$ that is independent of temperature. The sample used for this measurement was the initial commissioning

Table 1: Values for measured and expected R_S for a bulk niobium sample. Uncertainties for measured R_S are statistical values only.

T (K)	R_S exp. ($\mu\Omega$)	R_S meas. ($\mu\Omega$)	ΔR_S ($\mu\Omega$)
2.1	0.2	23.5 ± 1.4	23.3
3	1.9	23.8 ± 1.2	21.9
4	6.2	27.8 ± 0.6	21.6
4.5	9.0	30.5 ± 0.6	21.5

sample of the HZB QPR and for that reason, we know that this data cannot be a true R_{res} . However, this sample was brazed into a stainless steel flange without niobium coating and the measured values could be explained by strong parasitic losses on the bottom flange. This issue will be studied further in measurements with coated adapter flanges and QPR samples with known R_{res} .

OUTLOOK AND NEXT STEPS

We introduced RaSTA, a compact sample test cavity for measuring the R_S of QPR samples at 4.8 GHz using a cylindrical cavity operating in the TM_{020} mode. First cooldown results successfully demonstrate the proof-of-concept with a bulk niobium sample. The next commissioning steps are

- Adjustment of the input coupling for $\beta \approx 1$
- Extension of the RF system to precisely measure and control the RF field on sample
- Study of parasitic losses, especially by using niobium-coated sample adapter flanges
- Tolerance study for geometric asymmetries towards an analysis of systematic errors

Up to now, the outer diameter of the prototype cavity is too large to fit into the intended small LHe cryostat. The above listed commissioning steps and improvements are planned to result in an improved cavity design, finally enabling the rapid characterization of SRF materials and thin films under RF fields.

ACKNOWLEDGEMENTS

The commissioning of RaSTA is part of the joint research program NOVALIS, funded by the German ministry of education and research (BMBF), Förderkennzeichen 05K22CB1. In this framework and based on the successful collaboration on coating QPR samples and adapter flanges, the three parts of the cavity were coated with niobium by A. Zubitsovskii (University of Siegen). Also being a member of the NOVALIS collaboration, W. Ackermann (Technical University of Darmstadt) contributed with numerical work on the RF properties of the cavity.

The authors would like to thank A. Frahm, H.-W. Glock and F. Glöckner for valuable input and assistance during design and assembly of the modified copper gaskets with RF contacts for the CF125 flanges.

REFERENCES

- [1] E. Mahner, S. Calatroni, E. Chiaveri, E. Haebel, and J. M. Tessier, "A new instrument to measure the surface resistance of superconducting samples at 400 MHz", *Rev. Sci. Instrum.*, vol. 74, pp. 3390-3394, 2003. doi:10.1063/1.1578157
- [2] S. Keckert, R. Kleindienst, O. Kugeler, D. Tikhonov, and J. Knobloch, "Characterizing materials for superconducting radiofrequency applications – A comprehensive overview of the quadrupole resonator design and measurement capabilities", *Rev. Sci. Instrum.*, vol. 92, p. 064710, 2021. doi:10.1063/5.0046971
- [3] S. Keckert and O. Kugeler, "Vorrichtung zur Ermittlung von Oberflächenwiderständen", Deutsches Patent- und Markenamt DE 10 2021 123 261, Sep. 08, 2021.
- [4] S. Keckert *et al.*, "Mitigation of parasitic losses in the quadrupole resonator enabling direct measurements of low residual resistances of SRF samples", *AIP Adv.*, vol. 11, p. 125326, 2021. doi:10.1063/5.0076715
- [5] H. Padamsee, J. Knobloch, and T. Hays, *RF Superconductivity for Accelerators*, 2nd ed. Wiley, 2008.